

Scientists design model to predict cellular drug targets against COVID-19

November 25 2020

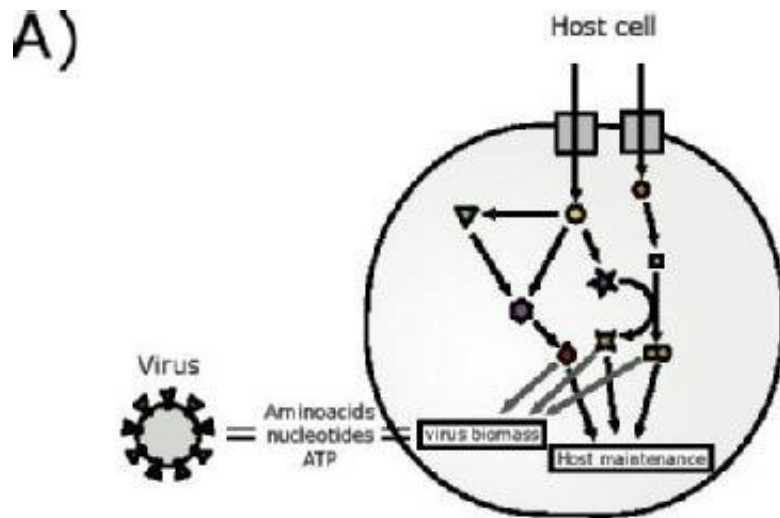

Credit: University of Warwick

A computational model of a human lung cell has been used to understand how SARS-CoV-2 draws on human host cell metabolism to reproduce by researchers at the University of Warwick. This study helps understand how the virus uses the host to survive, and enable drug predictions for treating the virus to be made.

Viruses rely on their host to survive, a crucial step of lifecycle is the synthesis of the virus particles within the [host cell](#), therefore understanding this process is key to finding ways to prevent the virus

from surviving.

Using a computer model of a human lung cell metabolism, scientists from the School of Life Sciences at the University of Warwick have captured the stoichiometric amino and nucleic acid requirements of SARS-CoV-2, the virus that causes Covid-19. Publishing their results in the paper, "Inhibiting the reproduction of SARS-CoV-2 through perturbations in human lung cell metabolic network," in the journal *Life Science Alliance*.

Their model has identified host-based metabolic perturbations inhibiting SARS-CoV-2 reproduction, highlighting reactions in the central metabolism, as well as amino acid and nucleotide biosynthesis pathways. In fact, researchers found that only few of these metabolic perturbations are able to selectively inhibit virus reproduction.

Researchers have also noted that some of the catalyzing enzymes of such reactions have demonstrated interactions with existing drugs, which can be used for experimental testing of the presented predictions using gene knockouts and RNA-interference techniques.

Professor Orkun Soyer, from the School of Life Sciences at the University of Warwick comments, "We have created a stoichiometric biomass function for the COVID-19-causing SARS-CoV-2 [virus](#) and incorporated this into a human lung cell genome scale metabolic model.

"We then predicted reaction perturbations that can inhibit SARS-CoV-2 reproduction in general or selectively, without inhibiting the host metabolic maintenance. The predicted reactions primarily fall onto glycolysis and oxidative phosphorylation pathways, and their connections to amino acid biosynthesis pathways."

Dr. Hadrien Delattre, from the School of Life Sciences at the University

of Warwick adds, "Together, these results highlight the possibility of targeting host metabolism for inhibition of SARS-CoV-2 reproduction in human cells in general and in human lung cells specifically.

He added, "More research needs to be carried out to explore SARS-CoV-2 infected [cells](#) and their metabolism, however the model developed here by the researchers can be used as a starting point for testing out specific drug predictions."

More information: Hadrien Delattre et al, Inhibiting the reproduction of SARS-CoV-2 through perturbations in human lung cell metabolic network, *Life Science Alliance* (2020). [DOI: 10.26508/lsa.202000869](https://doi.org/10.26508/lsa.202000869)

Provided by University of Warwick

Citation: Scientists design model to predict cellular drug targets against COVID-19 (2020, November 25) retrieved 20 May 2023 from <https://medicalxpress.com/news/2020-11-scientists-cellular-drug-covid-.html>

<p>This document is subject to copyright. Apart from any fair dealing for the purpose of private study or research, no part may be reproduced without the written permission. The content is provided for information purposes only.</p>
--