

Researchers explore PKC role in lung disease

25 February 2013

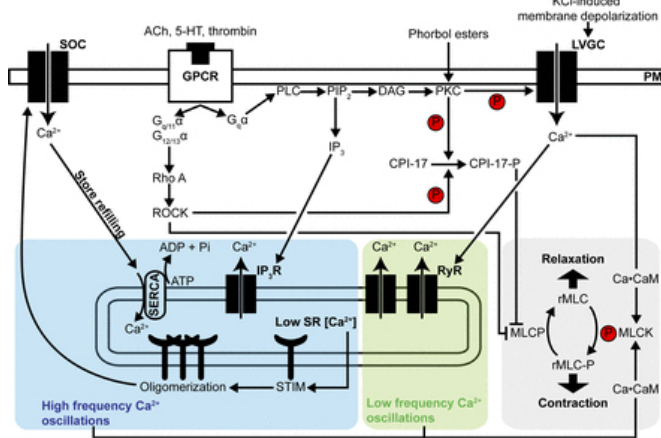

potential target for drug therapies.

The researchers used phase-contrast video microscopy, confocal microscopy, Western blot analysis, and pharmacological activators and inhibitors to investigate the role of PKC in airway SMC contraction in mouse lung slices. Their results suggest that activation of PKC in small airways promotes an influx of calcium into SMC and subsequent intracellular release of [calcium ions](#) to generate low frequency SMC twitching. PKC activation also induces a strong calcium ion sensitization of contraction, eliciting a stronger contractile response to stimuli that increase free intracellular calcium. Consequently, [PKC](#) activation downstream of various molecules, such as thrombin, that are present in the airways in conjunction with inflammatory [lung diseases](#), could sensitize the airway SMCs to contractile stimuli and contribute to the airway hyper responsiveness that is characteristic of asthma and COPD.

A *JGP* study examines the role of PKC in airway smooth muscle contraction and raises the possibility that this enzyme could be a therapeutic target for treating asthma, COPD, and other lung diseases. The diagram shown summarizes the pathways regulating airway smooth muscle contraction. Credit: Dixon, R.E., and L.F. Santana. 2013. *J. Gen. Physiol.*

More information: Dixon, R.E., and L.F. Santana. 2013. *J. Gen. Physiol.* 141:161 Mukherjee, S., et al. 2013. *J. Gen. Physiol.* 141:165-178.

New research examines the role of PKC in airway smooth muscle contraction and raises the possibility that this enzyme could be a therapeutic target for treating asthma, COPD, and other lung diseases.

Provided by Rockefeller University

In the lungs, pathological increases in the contraction of the [smooth muscle cells](#) (SMCs) lining airway walls—a process that decreases airflow—contribute to the chain of events leading to asthma and COPD, two common lung diseases. Jose Perez-Zoghbi and colleagues from Texas Tech University Health Sciences Center designed a series of experiments to investigate the role of the enzyme PKC in this process. The results, which appear in *The Journal of General Physiology*, provide new insight into the mechanisms involved in regulating luminal diameter of small airways and reveal PKC as a

APA citation: Researchers explore PKC role in lung disease (2013, February 25) retrieved 5 May 2021 from <https://medicalxpress.com/news/2013-02-explore-pkc-role-lung-disease.html>

This document is subject to copyright. Apart from any fair dealing for the purpose of private study or research, no part may be reproduced without the written permission. The content is provided for information purposes only.